



The CONTACTOR™

Published Monthly by Optimized Gas Treating, Inc.
Volume 12, Issue 12, December, 2018

Improve Acid Gas Enrichment via Enriched Gas Recycle

The H₂S content of the Amine Acid Gas (AAG) which comes from the regenerator in an amine treating unit can be very substantially increased by further treating in an Acid Gas Enrichment unit (AGE). The extent of the enrichment possible can be considerably increased if part of the enriched gas produced is recycled back to the enrichment (absorption) column. The strategy is shown in simplified schematic form in Figure 1. The process is called HIGHSULF™ (and HIGHSULF-PLUS™). It was first patented in 1996 (US Patent 5,556,606) and offered originally by the Tofik K. Khanmamedov Company, later The TKK Company. The most recently-issued, HIGHSULF patent (US 6,506,349) appears to have expired in July, 2017. It is our purpose here not to sell the technology, but to demonstrate the remarkable insightfulness of the concept itself, the simplicity of the process, and the astonishing benefit that can be had from its application.

SRUs based on Claus technology operate best with as high an H₂S level in the SRU feed as possible. But there is a lower H₂S limit below which the Claus SRU becomes very inefficient and requires the more complex processing associated with multiple reaction zones in the furnace, spiking with fuel gas to get the flame temperature high enough, and oxygen enrichment. The minimum H₂S concentration for an operable Claus plant is on the order of 20 mol%.; however, there are lots of gases that when processed contain much lower levels of H₂S in the AAG. And even if the H₂S content is above the minimum required, enriching the SRU feed from 20% to say 70% H₂S brings great benefit. Not least is higher plant capacity because the diluent CO₂ (75–80% in the worst case) fills a huge fraction of the gas volume that could be used by H₂S, and therefore it represents a costly capacity loss for the unit.

HIGHSULF technology is applicable to acid gas enrichment operations. There are numerous configurations possible but for the purpose of demonstration, the simplest is sufficient. Figure 1 shows an AGE flowsheet with a HIGHSULF recycle stream. The key of course is the acid gas recycle stream which returns a more concentrated form of H₂S from the regenerator acid gas into the original weak feed gas. The combined acid gas feed and recycled acid gas presents to the absorber a gas with a higher H₂S level. Naturally, the AGE absorber concentrates this even further so the acid gas from the regenerator ultimately strengthens. And this is the now much enriched feed to the SRU.

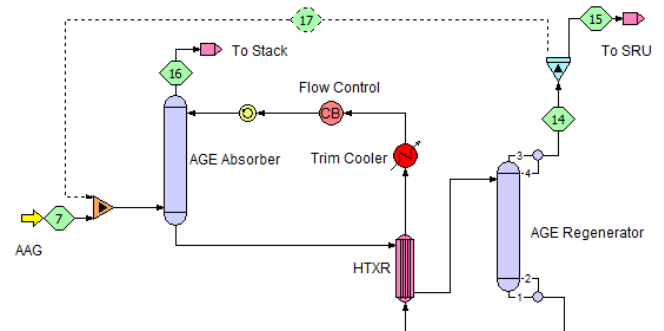

Figure 1 SRU with HIGHSULF™

The AGE absorber's ability to concentrate H₂S is limited by the H₂S concentration in the feed gas. A weak feed will concentrate to a lower level than an already rich feed will. Therefore, the recycle (dashed line shown as Stream 17 in Figure 1) artificially raises the feed concentration. In one sense, recycling acid gas seems counterproductive because the system is reabsorbing already processed acid gas and restripping it from the solvent. The repeated reabsorption and restripping consumes energy; however, the result is a more concentrated SRU feed. The degree of concentration afforded can be so great that an Amine Acid Gas (AAG) that would be utterly unprocessable in an SRU (e.g., 10% H₂S) can be enhanced to 50–60% H₂S just by employing the recycle.

Case Study 1: Enriching Marginal H₂S AAG

A 25 MMscfd AAG stream contains 34% H₂S, 64% CO₂ and 1% each of methane and ethane and is at 15 psig and 120°F. This is at the lower operability end of a straight-through SRU but it can be enriched considerably by treating with MDEA. The solvent is 3,500 USgpm of 45 wt% MDEA at 120°F. The absorber contains 20 conventional valve trays and is sized for 70% flood. Regenerators contain 30 trays with 120°F condensers. Reboiler conditions are 15 psig and 275 MMBtu/h duty. The main constraint is that gas to incineration cannot exceed 75 ppmv H₂S. This is a somewhat arbitrary stipulation but it ensures that comparisons are done under the same requirements.

Conventional AGE Unit

The conventional scheme is the flowsheet shown in Figure 1

without the dashed recycle line. ProTreat® simulations predict that enrichment to 62% H₂S (wet basis) is possible, while sending only 40 ppmv H₂S to incineration. At 20 trays, the absorber appears to be over trayed. This means the H₂S leak is controlled principally by amine lean loading, which is a direct function of reboiler duty but, more importantly, the extra trays are removing CO₂ and diluting the SRU feed gas. When run with 10 trays in the AGE absorber, simulation indicates 73% H₂S in the SRU feed and 69 ppmv H₂S in the gas to incineration.

HIGHSULF with Combined Feeds

In its simplest implementation, HIGHSULF™ recycle gas is re-combined with raw feed. ProTreat simulation predicts that the quality of the SRU feed is a function of the extent of application of the HIGHSULF strategy, i.e., the percentage of regenerator acid-gas that is recycled. Figures 2 and 3 show how the degree of enrichment and the H₂S leak to the stack vary with increasing levels of recycle. As HIGHSULF is applied increasingly beyond 65%, the point is reached where H₂S leak to the stack suddenly escalates because the AGE absorber becomes overloaded, and H₂S breaks through into the incinerator gas. However, by the time this happens, the wet SRU feed has reached nearly 82% H₂S!

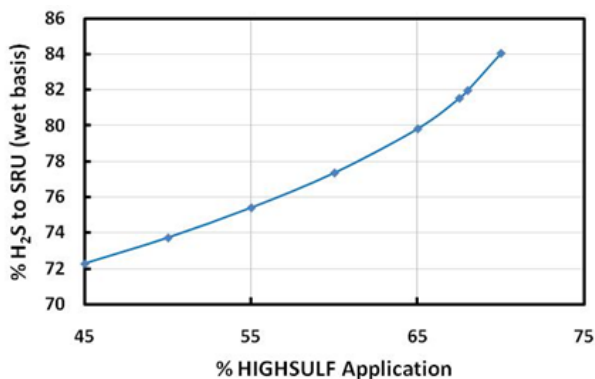

Figure 2 Percent H₂S in Wet Feed to SRU

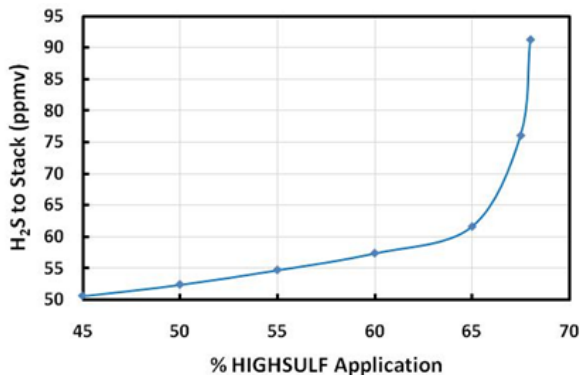

Figure 3 H₂S Leaked to Incineration

The best a conventional AGE unit could do under iden-

tical conditions of flow and energy usage was 72% H₂S. Obviously there is a limit to how vigorously HIGHSULF can be applied before the operation collapses. However, it is remarkable that when the optimal extent of HIGHSULF™ is applied, the SRU feed quality can be increased so much for zero operating cost that the dry gas now contains 87% H₂S and only 13% CO₂.

Case Study 2 — Enriching Low H₂S AAG

The acid gas flow is the same as in Case Study 1 — 25 MMscfd, but the H₂S content is only 8%, with CO₂ at 90% and methane and ethane making up 1% each. Because there is less H₂S to be removed, the solvent flow used is 1250 USgpm at 120°F. All other conditions are the same as in Case Study 1.

ProTreat™ simulation of a conventional AGE unit with 20 absorber trays, upgrading is from 8% to 33.7% H₂S but again the absorber is over trayed. When the absorber contains only 10 trays, the maximum application of HIGHSULF as configured in Figure 1 and consistent with meeting the 75 ppmv H₂S specification on incinerator gas is about 53%. This gives a dry-basis SRU feed of 54% H₂S, representing about a 15% improvement over a conventional AGE plant.

As is the case with treating moderately-high H₂S gas, when HIGHSULF is over applied the AGE contactor becomes overloaded and breakthrough occurs. This causes rapid escalation of H₂S in the incinerator gas. However, a 15% improvement over conventional treating can be had for essentially zero operating expense and vanishingly-small capital cost (controller and duct work or pipe). There are no additional operating costs because the recycled acid gas moves from the regenerator at 12–18 psig to the absorber at atmospheric pressure—no blower is required.

It appears that applying HIGHSULF technology always leads to better AGE unit performance over a conventional AGE unit. Even if higher H₂S content is not required for good sulphur plant operation itself, eliminating CO₂ reduces the gas load on a sulphur plant, thereby increasing its capacity and the sulphur recovery level.

Because potentially the entire gas stream can be absorbed, an amine-based AGE unit is quite a severe test of one's ability to model selectivity at this level. Gas flow and composition vary rapidly throughout the contactor, and concentration profiles can become inverted, even forming an H₂S bubble within the contactor. The key is mass-transfer rate-based modeling using the ProTreat® simulator's sound, predictive engineering science, not rules of thumb and forced fitting.

To learn more about this and other aspects of gas treating, plan to attend one of our training seminars. Visit www.pro-treat.com/seminars for details.

ProTreat® and **The Contactor™** are trademarks of Optimized Gas Treating, Inc. Any other trademarks are the property of their owner.